

Kubota

KUBOTA HORIZONTAL WATER-COOLED DIESEL ENGINE



RK/ER/KND Series

Displacement: 305 cc~1,181 cc

Maximum Output: 5.0 HP~25.0 HP

RK50 RK50-N RK50H RK50-NB

SPECIFICATIONS

RK70-N



RK80-1



RK95-1-NB



RK105H-2



RK125-2



ER2200DI-N



ER2500DI-N



Model	RK50	RK50-N	RK50H	RK50-NB
Type	Horizontal water-cooled, 4-cycle diesel engine			
Number of cylinders	1			
Bore x stroke [mm (in.)]	72 x 75 (2.83 x 2.95)			
Displacement [cc (cu.in.)]	305 (18.61)			
Maximum output (HP/r.p.m.) (kW/r.p.m.)	5.0/2400 3.73/2400			
Continuous rated output (HP/r.p.m.) (kW/r.p.m.)	4.5/2200 3.36/2200			
Maximum torque (kgf·m/r.p.m.)	1.62/1800			
Specific fuel consumption (at continuous rated output) (g/HP-hr)	208			
Combustion system	Three vortex combustion system			
Compression ratio	24			
Direction of revolution	Counter-clockwise (facing flywheel)			
Starting system	Manual speed-doubling handle		Cell start	
Lubricating system	Forced lubrication with trochoid pump			
Cooling system	Radiator		Hopper Radiator	
Fuel	Light diesel oil (SAE No.2-D)			
Lubricating oil	API service CB-CC class (SAE #30, 20, 10W-30)			
Cooling water capacity [L (US gal.)]	1.3 (0.34)		8.5 (2.25) 1.3 (0.34)	
Fuel tank capacity [L (US gal.)]	7.5 (1.98)			
Crankcase oil capacity [L (US gal.)]	2.0 (0.53)			
Dry weight [kg (lbs.)]	64 (141.1)		62 (136.7) 72 (158.8)	
Lamp and dynamo output (V-W)	with lamp 12-45		without lamp —	
Charge output (V-A)	—		12-1.6	
Starter power (V-kW)	—		12-1.0	

PERFORMANCE CURVES

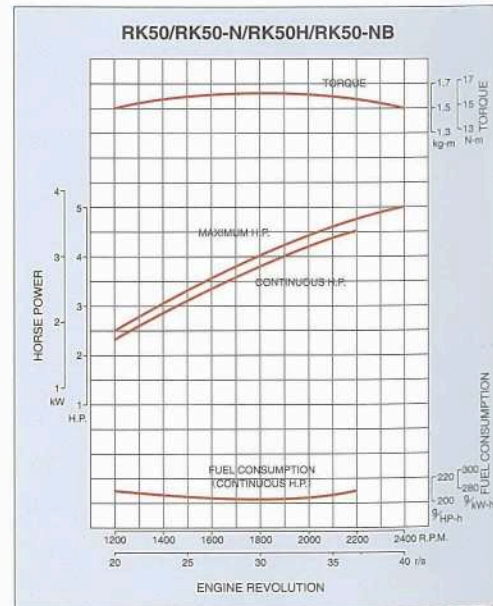

DIMENSIONS (mm)

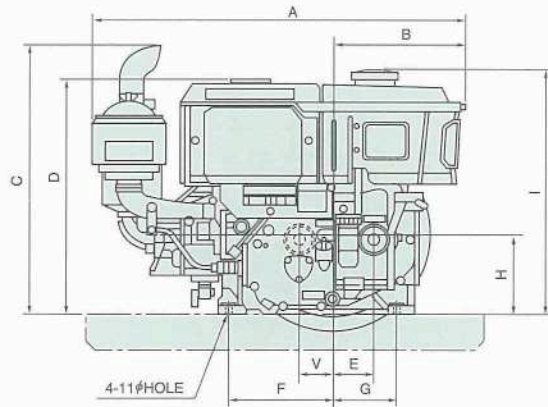
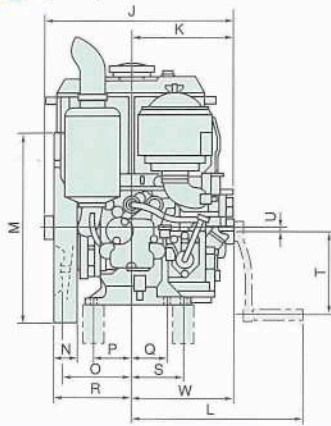

Model	A	B	C	D	E	F	G	H	I	J	K	L	M	N	O	P	Q	R	S	T	U	V	W
RK50(N)	650	236	492	419	—	182	103	140	435	322.5	175.5	306	Ø355	29	120	70	70	124	—	154	12	64.4	171
RK60(N)	650	236	492	419	—	182	103	140	435	322.5	175.5	306	Ø355	36	120	70	70	131	—	154	12	64.4	171
RK70(N)	650	236	492	419	—	182	103	140	435	322.5	175.5	306	Ø355	43	120	70	70	138	—	154	12	64.4	171
RK80-1(N)	715	251	516	448.5	77.6	199	124	150	467	358	196	334	Ø362	36	132.5	72	68	140	98	160	8	—	—
RK95-1(N)	715	251	516	448.5	77.6	199	124	150	467	358	196	334	Ø370	43	132.5	72	68	147	98	160	8	—	—
RK105-2(N)	755.5	259	521	458.5	80.5	212	111	155	474	369.5	201.5	341.5	Ø380	45	135.5	75	95	152	—	170	10	—	—
RK125-2(N)	755.5	259	521	458.5	80.5	212	111	155	474	369.5	201.5	341.5	Ø380	50	135.5	75	95	157	—	170	10	—	—

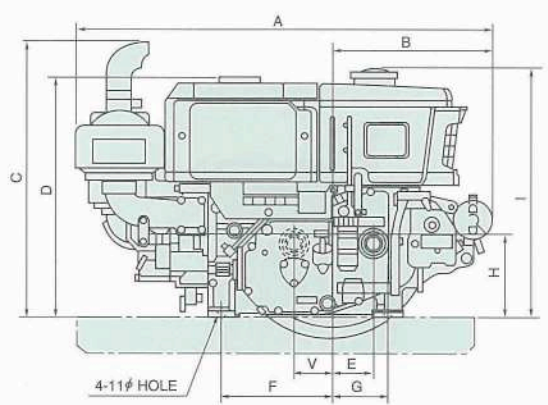
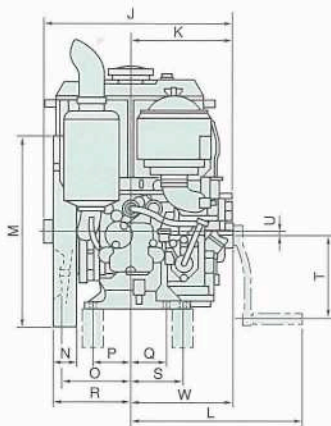

Model	A	B	C	D	E	F	G	H	I	J	K	L	M	N	O	P	Q	R	S	T	U	V	W
RK50NB	664.5	250.5	492	419	—	182	103	140	435	322.5	175.5	306	Ø350	42	120	70	70	144	—	154	12	64.4	171
RK60NB	664.5	250.5	492	419	—	182	103	140	435	322.5	175.5	306	Ø350	42	120	70	70	144	—	154	12	64.4	171
RK70NB	664.5	250.5	492	419	—	182	103	140	435	322.5	175.5	306	Ø350	42	120	70	70	144	—	154	12	64.4	171
RK80-1NB	763	299	516	448.5	77.6	199	124	150	467	358	196	334	Ø370	40	132.5	72	68	147	98	160	8	—	—
RK95-1NB	763	299	516	448.5	77.6	199	124	150	467	358	196	334	Ø370	40	132.5	72	68	147	98	160	8	—	—
RK105-2-NB	802	306	521	458.5	80.5	212	111	155	474	369.5	201.5	341.5	Ø380	45	135.5	75	95	150	—	170	10	—	—
RK125-2-NB	802	306	521	458.5	80.5	212	111	155	474	369.5	201.5	341.5	Ø380	45	135.5	75	95	150	—	170	10	—	—

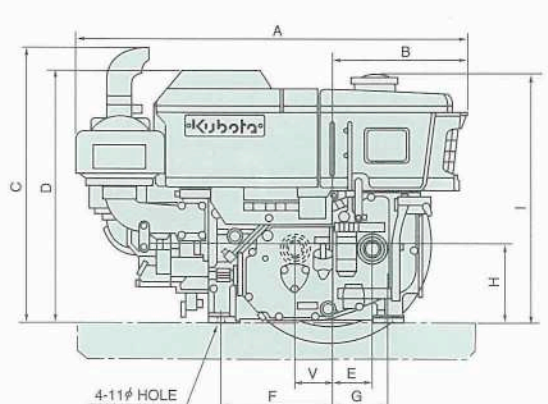
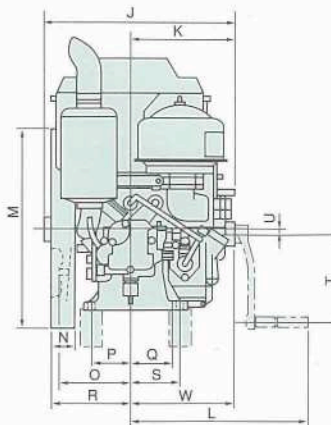

Model	A	B	C	D	E	F	G	H	I	J	K	L	M	N	O	P	Q	R	S	T	U	V	W
RK50H	645	231	492	452	—	182	103	140	436	322.5	175.5	306	Ø355	29	120	70	70	124	—	154	12	64.4	171
RK60H	645	231	492	452	—	182	103	140	436	322.5	175.5	306	Ø355	36	120	70	70	131	—	154	12	64.4	171
RK70H	645	231	492	452	—	182	103	140	436	322.5	175.5	306	Ø355	43	120	70	70	138	—	154	12	64.4	171
RK80H-1	710	246	516	471	77.6	199	124	150	467	358	196	334	Ø362	36	132.5	72	68	140	98	160	8	—	—
RK95H-1	710	246	516	471	77.6	199	124	150	467	358	196	334	Ø370	43	132.5	72	68	147	98	160	8	—	—
RK105H-2	750.5	254	521	481	80.5	212	111	155	474	369.5	201.5	341.5	Ø380	50	135.5	75	95	157	—	170	10	—	—
RK125H-2	750.5	254	521	481	80.5	212	111	155	474	369.5	201.5	341.5	Ø380	50	135.5	75	95	157	—	170	10	—	—

RK SERIES

Detail of Flywheel

Surface to which flywheel adaptor is attached

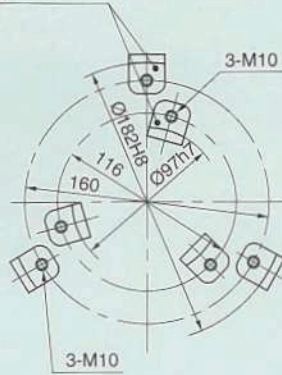

Optional PTO (Optional at extra cost)

- 14912-84514 (PTO shaft) 1 pc.
- 01153-51035 (Bolt) 3 pcs.
- 04512-50100 (Washer spring) 3 pcs.
- 05919-00750 (Key gradient) 1 pc.

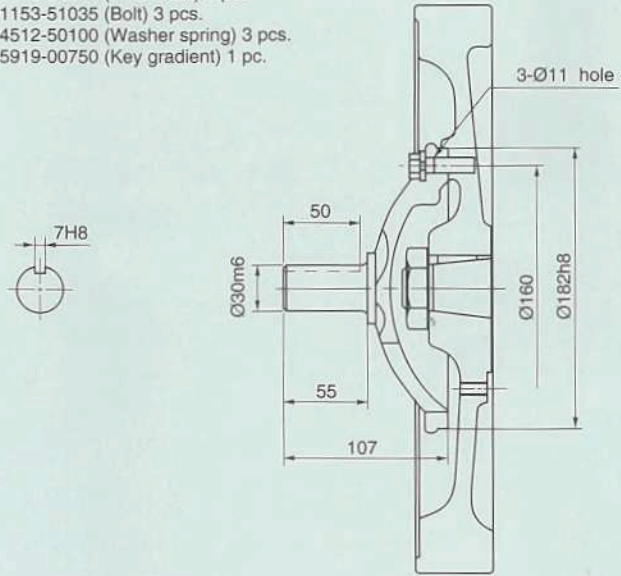

ER/KND SERIES

Detail of Flywheel

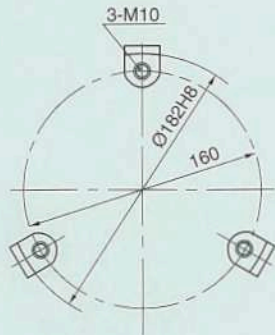

Optional PTO (Optional at extra cost)

- 14943-84413 (PTO shaft) 1 pc.
- 01153-51040 (Bolt) 3 pcs.
- 04512-50100 (Washer spring) 3 pcs.
- 05919-01280 (Key gradient) 1 pc.

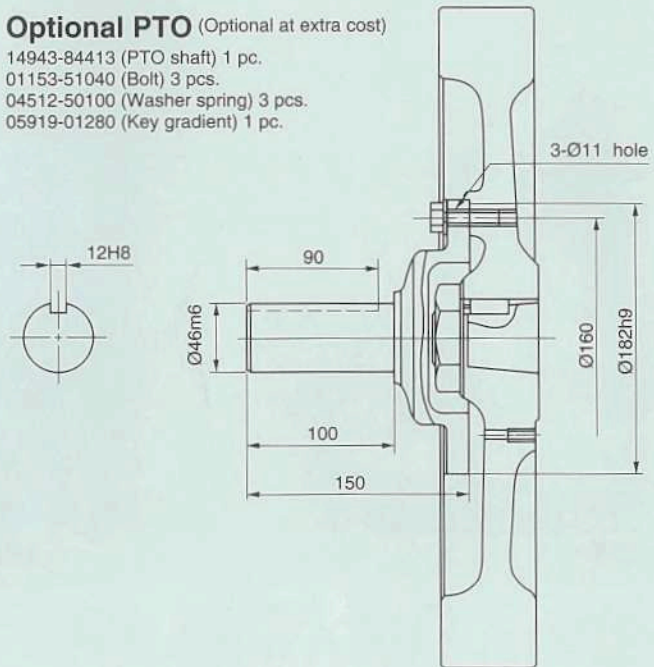

Standard Accessories

Model	RK SERIES	ER/KND SERIES
Fuel tank	1	1
Air cleaner	1	1
Muffler (silencer)	1	1
Engine eye bolt	1	1
Instruction manual	1	1
Maintenance tool bag	1	1
12-14mm box spanner	1	1
10-12mm spanner	1	1
14-17mm spanner	1	1
19-22mm spanner	1	1
+,- driver	1	1